

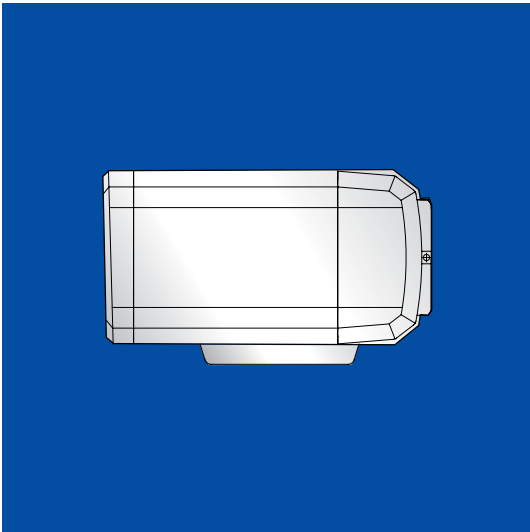





Digital Day & Night  
**COLOR CAMERA**

USER MANUAL







# DCC-500F



	<b>CAUTION</b> <b>RISK OF ELECTRIC SHOCK</b> <b>DO NOT OPEN</b>	
<p><b>CAUTION :</b>          TO REDUCE THE RISK OF ELECTRIC SHOCK,          DO NOT REMOVE COVER(OR BACK),          NO USER SERVICEABLE PARTS INSIDE.          REFER SERVICING TO QUALIFIED          SERVICE PERSONNEL.</p>		

	<p>The lightning flash with an arrowhead symbol, within an equilateral triangle is intended to alert the user to the presence of uninsulated dangerous voltage within the product's enclosure that may be of sufficient magnitude to constitute a risk of electric shock to persons.</p>
	<p>The exclamation point within an equilateral triangle is intended to alert the user to the presence of important operating and maintenance (servicing) instructions in the literature accompanying the appliance.</p>
<p><b>INFORMATION</b> - This equipment has been tested and found to comply with limits for a Class A digital device, pursuant to part 15 of the FCC Rules.          These limits are designed to provide reasonable protection against harmful interference when the equipment is operated in a commercial environment.          This equipment generates, uses, and can radiate radio frequency energy and, if not installed and used in accordance with the instruction manual, may cause harmful interference to radio communications. Operation of this equipment in a residential area is likely to cause harmful interference in which case the user will be required to correct the interference at his own expense.</p> <p><b>WARNING</b> - Changes or modifications not expressly approved by the manufacturer could void the user's authority to operate the equipment.</p>	
<p><b>CAUTION</b> : To prevent electric shock and risk of fire hazards : Do NOT use power sources other than that specified.          Do NOT expose this appliance to rain or moisture.</p>	
<p><b>This installation should be made by a qualified service person and should conform to all local codes</b></p>	

## ■ Warning

	<p><b>The camera needs periodic inspection.</b> Contact an authorized technician for inspection.</p>
	<p><b>Stop using your camera when you find a malfunction.</b> If you use your camera around smoke or unusual heat for a long time, fire may be caused.</p>
	<p><b>Do not install the camera on a surface that can not support it.</b> Unless the surface is suitable, it could cause falling or other hazards.</p>
	<p><b>Do not hold plug with wet hands.</b> It could cause an electric shock.</p>
	<p><b>Do not disassemble the camera.</b> It may result in fire, electric shock or other hazards.</p>
	<p><b>Do not use the camera close to a gas or oil leak.</b> It may result in fire or other hazards.</p>

## ■ Contents

<b>1. Features</b> .....	4
<b>2. Components &amp; Cable Connection</b> .....	6
<b>3. Names and functions of parts</b> .....	7
<b>4. Installation &amp; Dimension</b> .....	10
<b>5. Setup Menu Operation</b> .....	16
<b>6. Special Menu operation</b> .....	27
<b>7. Troubleshooting</b> .....	36
<b>8. Specifications</b> .....	38

## 1. Features

### **Horizontal Resolution 530 TVLines**

Clear image quality has been achieved by employing a SONY CCD with 410,000 (effective) pixels, which provides a horizontal resolution of 530 TV lines.

### **DAY & NIGHT**

This camera has a function that automatically selects the mode that is appropriate for daytime or night-time conditions. The COLOR mode operates in daytime conditions to provide optimum colors, and BW mode operates in nighttime conditions to enhance the definition of the image.

### **Electronic IRIS**

The electronic IRIS function enables continuous automatic control of the shutter between 1/60~1/120,000 seconds.

### **PRIVACY Function**

The PRIVACY function conceals the areas you do not wish to appear on the screen.

### **High Sensitivity**

The built-in high sensitivity SONY COLOR CCD enables a clear image even in 0.3Lux(0.1Lux B/W) or as low as 0.002Lux with SENS-UP.

### **DNR (Digital Noise Reduction)**

The amount of low illuminance noise has been significantly reduced, and the signal-to-noise ratio (S/N ratio) as well as horizontal resolution have been improved, resulting in a clear and sharp image display even in the dark.

### **Controlled by OSD Menu**

The camera can be controlled by selecting text displayed on the monitor screen.

### **Additional Functions**

SENS-UP, MOTION DETECTION, MIRROR, SHARPNESS and SYNC (INT/LL) functions are also available.

## 2. Components

### 1) COLOR CAMERA



### 2) AUTO IRIS LENS CONNECTION PLUG



### 3) C-MOUNT ADAPTOR



### 4) L-WRENCH



### 5) MANUAL



## 3. Names and Functions of Parts

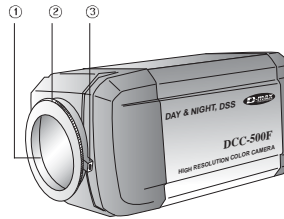

### 1) Front

#### ① Lens protection cap

Please cover the lens when not using it.

#### ② CS-Mount lens adaptor

Please attach the CS-Mount lens here.

#### ③ Back Focus clamp screw

Please loosen the clamp screw with a screwdriver before adjusting the Back Focal length.

#### ☞ Mounting bracket screw hole

Please use the screw hole when fixing the camera onto the mounting bracket. Please use the clamp screw as specified picture.

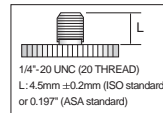

☞ The mounting bracket can be separated and attached to the top of the camera.  
In this instance please do not tighten the screw to a depth of more than 5mm, otherwise serious damage can occur to the inside of the camera.

## 2) Back

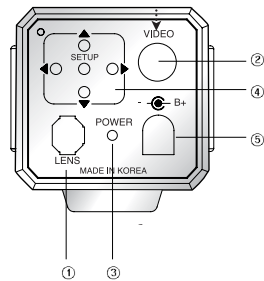

### ① Auto iris lens connector

This is the connection terminal for the auto iris lens.

### ② Video output terminal

Sends video signals and connects to the video input terminal of the monitor.

### ③ Power lamp

Lights up when the correct power is supplied to the camera.

### ④ Setting button

**SETUP button** : Used for the menu display.  
This button can be used to confirm settings after changing the value of the selected function or current conditions.

**UP & DOWN button** : Used for selecting items by moving the cursor up or down on the menu screen.

**LEFT & RIGHT buttons** : Used when changing item values, by moving the cursor to the left or right on the menu screen.

### ⑤ Power input terminal

Connects to the power appropriate to each power requirement.

## 4. Installation

### 1) Lens

Lenses are sold separately. Lenses such as auto iris lens, CS-Mount lens and C-Mount lens can be used.

#### Note

- Use of the DC auto iris lens is recommended to achieve the best results for operating this product effectively.
- Please keep the lens clean.
- Any foreign objects and fingermarks on the lens can cause inferior image quality in low light level conditions.

#### ① When using an auto iris lens

- Please peel off about 8mm of the outer skin of the auto iris lens cable.

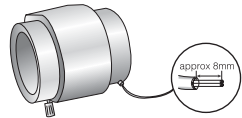

- Please peel off about 2mm of the outer skin of the insulated conductor inside the lens cable

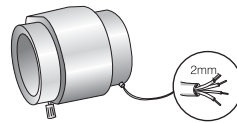

- Please remove the cover of the auto iris lens connection plug and solder the lens cable to the connector pin in the plug.

Pin No.	LENS	
	DC	VIDEO
No.1 Pin	Damping-	Red(power)
No.2 Pin	Damping+	NC
No.3 Pin	Drive+	White(video signal)
No.4 Pin	Dre-	Black(GND)

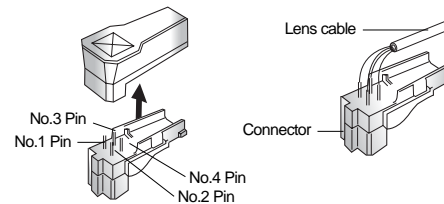

- Please replace the auto iris lens connection plug cover and take off the lens protection cap, and

then attach the auto iris lens to the camera by screwing it in clockwise.

- Please insert the connection plug that is connected to the auto iris lens cable into the auto lens connector, which is located on the back of the camera

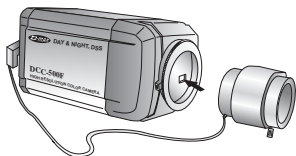

- Please set the lens selection switch, located on the back of the camera, to DC or VIDEO depending on the type of auto iris lens which is being used.

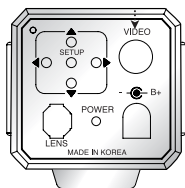

### ② When using a CS-Mount lens

Please take off the lens protection cap and attach the CS-Mount lens to the camera by screwing it in clockwise.

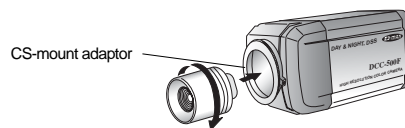

### ③ When using a C-Mount lens

- Please take off the lens protection cap and attach the C-mount adaptor.

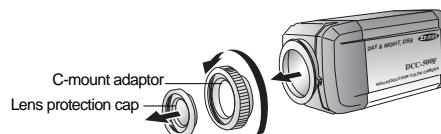

- Please attach the C-Mount lens to the camera by screwing it in clockwise.

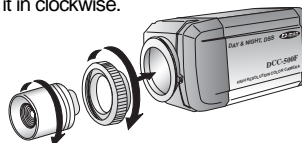



**Note**

- Please use the specified lens connection parts as shown in the picture below.  
The use of the wrong sized parts may cause damage to the inside of the camera or result in poor fitting.
- Use of a lens which is too heavy affects the balance of the camera and may cause a malfunction.  
Please use a lens that weighs less than 450g.
- Please select Av mode if possible when adjusting the automatic light control (ALC) of an auto lens.  
Use of PK mode may cause hunting

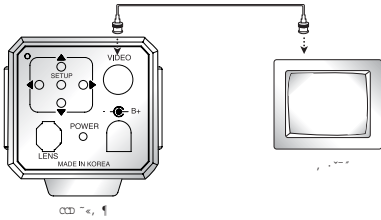
**2) Connecting to a monitor**

Please connect the video output terminal located on the back of the camera to the monitor.

- The connection method varies depending on

the type of monitor and accessories.

Please refer to the user's manual for each instrument.

- Please turn off the power when connecting.

**3) Connecting to power**

DC Power Type (DC 12V, 500mA)

## 5. Setup Menu Operation

### 1) Settings

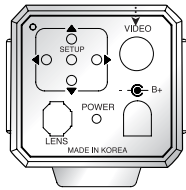

- ① Please press the SETUP button. Settings can now be made. The SETUP menu is displayed on the monitor.
- ② Please select any function you wish to activate by using the UP and DOWN buttons.

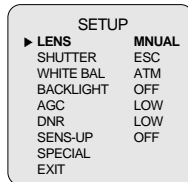

The arrow can be moved up or down by using the UP and DOWN buttons.

Please position the arrow to point to the function you wish to operate.

Select any function you wish to operate by using the UP and DOWN buttons.

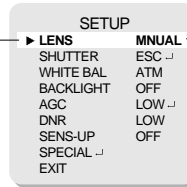

Modes can be changed using the LEFT and RIGHT buttons.

- ③ Please press the LEFT or RIGHT button if you wish to change mode.  
When the LEFT or RIGHT button is pressed, available values and modes are displayed in order. Please keep pressing the button until you get to the mode you wish to operate.
- ④ Please select 'EXIT' and then press the SETUP button to finish the setting.

#### Note

- If appears at the mode you wish to operate, it means that there is a sub-menu which can be selected by pressing the SETUP button.
- If appears at the mode item, it means that there is no mode available to be selected.

### 2) LENS

This function is used to adjust the brightness of the screen.

SETUP	
▶ LENS	DC
SHUTTER	ESC
WHITE BAL	ATM
BACKLIGHT	OFF
AGC	LOW
DNR	LOW
SENS-UP	OFF
SPECIAL	
EXIT	

① When the SETUP menu is displayed on the screen, please position the arrow to point to 'LENS' by using the UP and DOWN buttons.

- ② Please select the type of the lens you wish to use by pressing the LEFT or RIGHT Button
- ③ Please press the SETUP button if you wish to return to the previous menu
- ④ **MANUAL** : Manual lens selection
- ⑤ **DC** : Auto iris lens selection

#### Note

- The brightness of the screen can be adjusted in DC mode. The brightness can be adjusted within the range of 1 ~ 70. The optimum level of brightness for the user can be achieved by adjustment.
- If you select the MANUAL mode, it can be adjusted in ESC mode.

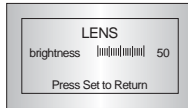

### 3) SHUTTER

Auto or manual control can be selected.

SETUP	
LENS	MNUAL
▶ SHUTTER	ESC
WHITE BAL	ATM
BACKLIGHT	OFF
AGC	LOW
DNR	LOW
SENS-UP	OFF
SPECIAL	
EXIT	

① When the SETUP menu is on the screen, please position the arrow to point to SHUTTER' by using the UP and DOWN buttons.

- ② Please select the **ESC** shutter mode by pressing the LEFT or RIGHT button.
  - **FLK** : Please select 'FLK' mode when flickering occurs on the screen, due to an imbalance between illumination and frequency. (NTSC Model:1/100, PAL Model: 1/120)
  - **ESC** : Auto control of the shutter speed can be achieved. When ESC mode is on, the speed is controlled automatically according to the brightness of the screen.
  - **MANUAL** : The shutter speed can be controlled manually.

SETUP	
▶ LENS	MNUAL
SHUTTER	ESC ↵
WHITE BAL	ATM
BACKLIGHT	OFF

- ③ Please select 'MANUAL' mode if you wish to adjust the shutter manually.  
 - You can select speed from '1/60' to '1/120,000'sec (NTSC Models), '1/50' to '1/120,000'sec (PAL Models).
- ④ Please press the SETUP button when all the settings are complete.

#### Note

- While using the internal synchronous system, if the shutter setting is on 'ESC' and the camera is directly facing a bright fluorescent light, the image on the screen can dirersely affected. Therefore please choose the installation location with care.
- When 'MANUAL' mode is on, the SENS UP function does not operate.

#### 4) WHITE BALANCE

SETUP	
LENS	MNUAL
SHUTTER	ESC
▶ WHITE BAL	ATM
BACKLIGHT	OFF
AGC	LOW
DNR	LOW
SENS-UP	OFF
SPECIAL	
EXIT	

The screen color can be adjusted by using the WHITE BALANCE function.

- ① Please position the arrow to point to 'WHITE BAL' on the SETUP menu by using the UP and DOWN buttons
- ② Please select the mode you wish to operate by pressing the LEFT or RIGHT button.

- **ATW(Auto Tracking White Balance)** : This mode can be used within the color temperature range 1,800°K ~ 10,500°K (eg, fluorescent light, outdoor, sodium vapor lamp or inside tunnels)
- **AWC(Auto White Balance Control)** : Please press the SETUP button while the camera is directed at a piece of white paper to obtain the optimum state under current illumination. If the environment including the light source is changed you have to adjust the white balance again.
- **MANUAL** : The manual adjustment mode enables finer adjustment.  
 Please select ATW or AWC first. Please change to manual adjustment mode and press the SETUP button. Please set the appropriate color temperature, and then increase or decrease the red and blue color values while monitoring the color changes on the object.

**Note**

• Under the following conditions the WHITE BALANCE function may not operate properly. In such cases, please select the AWC mode. When the object's surroundings have a very high color temperature (eg, a clear sky and sunset)

When the object's surroundings are dark If the camera directly faces a fluorescent light or is installed in a place where there are considerable changes in illumination, the WHITE BALANCE function may become unstable.

**5) BACKLIGHT**

When there is a strong backlight behind the object, clear images of the background as well as the object can still be obtained by using the backlight function.

SETUP	
LENS	MNUAL
SHUTTER	ESC
WHITE BAL	ATM
▶ BACKLIGHT	OFF
AGC	LOW
DNR	LOW
SENS-UP	OFF
SPECIAL	
EXIT	

- ① Please position the arrow to point to 'BACKLIGHT' on the SETUP menu by using the UP and DOWN buttons.

- ② Please select the mode you wish to operate by pressing the LEFT or RIGHT button.

- **HIGH** : The gain increases from 0dB up to 42dB.
- **MIDDLE** : The gain increases from 0dB up to 30dB.
- **LOW** : The gain increases from 0dB up to 18dB.
- **OFF** : BACKLIGHT function does not operate.

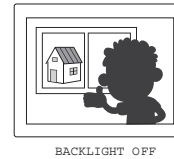
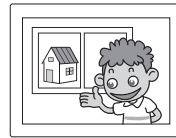
**6) AGC (AUTO GAIN CONTROL)**

SETUP	
LENS	MNUAL
SHUTTER	ESC
WHITE BAL	ATM
BACKLIGHT	OFF
▶ AGC	LOW
DNR	LOW
SENS-UP	OFF
SPECIAL	
EXIT	

- ① Please position the arrow to point to 'AGC' on the SETUP menu by using the UP and DOWN buttons.
- ② Please select the mode you wish to operate by pressing the LEFT or RIGHT button.

As the level of gain increases, the screen gets brighter and the level of noise also increases.

- **HIGH** : The gain increases or decreases within the range of 6dB ~ 42dB.
- **MIDDLE** : The gain increases or decreases within the range of 6dB ~ 30dB.
- **LOW** : The gain increases or decreases within the range of 6dB ~ 18dB.
- **OFF** : The gain is fixed at 6dB.

## 7) DNR

The background noise in the low light level decreases automatically as the level of gain changes.

SETUP	
LENS	MNUAL
SHUTTER	ESC
WHITE BAL	ATM
BACKLIGHT	OFF
AGC	LOW
▶ <b>DNR</b>	<b>LOW</b>
SENS-UP	OFF
SPECIAL	
EXIT	

① Please position the arrow to point to 'DNR' on the SETUP menu by using the UP and DOWN buttons.

② Please select the mode you wish to

operate by pressing the LEFT or RIGHT button.

- **OFF** : There is no reduction in noise level.
- **LOW** : There is a small reduction in noise level with almost no ghost image.

- **MIDDLE** : The most effective mode. There is a sufficient reduction in noise levels without causing much ghost imaging.

- **HIGH** : The level of noise is reduced greatly, however there is an increase in ghost imaging.

### Note

- When AGC is turned off, DNR does not operate.

## 8) SENS UP

SENS UP helps maintain a bright, clear screen image by automatically detecting changes in the level of light in low light level conditions

SETUP	
LENS	MNUAL
SHUTTER	ESC
WHITE BAL	ATM
BACKLIGHT	OFF
AGC	LOW
DNR	LOW
▶ <b>SENS-UP</b>	<b>OFF</b>
SPECIAL	
EXIT	

① Please position the arrow to point to 'SENS UP' on the SETUP menu by using the UP and DOWN buttons.

② Please select the mode you wish to operate by pressing the LEFT or RIGHT button.

③ Please press the SETUP button when all the settings are complete.

④ The maximum storage magnification in low light level movement situations can be adjusted

by pressing the SETUP button in 'AUTO' mode.(X2~X128)

- ⑤ As the magnification increases, the screen gets brighter; however the after image also increases
- ⑥ If storage magnification is increased while SENS UP is operating, it may cause noise, and spots may appear; however this is normal.
- ⑦ **AUTO** : Low light level auto mode
- ⑧ **OFF** : The function does not operate

#### Note

- When SHUTTER is in the manual mode, SENS UP does not operate.
- When AGC is turned off, SENS UP does not operate.

#### 9) EXIT

Saves all the setting menus and then exits.

## 6. Special Menu Operation

### 1) SPECIAL MENU

SETUP	
LENS	MNUAL
SHUTTER	ESC
WHITE BAL	ATM
BACKLIGHT	OFF
AGC	LOW
DNR	LOW
SENS-UP	OFF
▶ SPECIAL	
EXIT	

- ① Please position the arrow to point to 'SPECIAL' on the SETUP menu by using the UP and DOWN buttons.
- ② Please select the mode you wish to operate by pressing the UP or DOWN button

### 2) CAMERA ID

If the ID is input, the camera ID appears on the monitor.

SETUP	
▶ CAMERA ID	OFF
COLOR	ON
SYNC	INT
MOTION DET	OFF
PRIVACY	OFF
MIRROR	OFF
SHARPNESS	ON
RESET	
RETURN	

- ① Please position the arrow to point to 'CAMERA ID' by using the UP or DOWN button.
- ② Please select 'ON' by pressing the LEFT or RIGHT button.
- ③ Please press the SETUP button.

## Camera ID

```

ABCDEFGHIJKLM
NOPQRSTUVWXYZ
abcdefghijklmnopqrstuvwxyz
-. 0123456789
← → CLR POS END
-----

```

## ④ Up to 15 letters can be used for the ID.

- Please move the cursor to the letter you wish to choose by using the UP and DOWN button.

## Camera ID

```

ABCDEFGHIJKLM
NOPQRSTUVWXYZ
abcdefghijklmnopqrstuvwxyz
-. 0123456789
← → CLR POS END
-----

```

- Select an ID from A,B~Y,Z, a,b~y,z, 0,1~8,9 by using the UP, DOWN,LEFT and RIGHT buttons.
  - Please lock in the letters by using the SETUP button.
- When the letter is locked in, the cursor moves to the next space.
- Please repeat the above to input the ID.

**Note**

## • If the wrong name has been input.....

If you press the SETUP button after moving the cursor to CLR, all the letters will be erased. If you want to correct a letter, please move the cursor to the arrow at the bottom left of the screen and press 'SET'.

Please position the cursor above the letter you wish to correct, and then move the cursor onto the letter you wish to choose and press the SETUP button.

- When a name has been chosen, please select a position for the name display.

- Please move the cursor onto 'POS' and then press the SETUP button.

## Camera ID

```

ABCDEFGHIJKLM
NOPQRSTUVWXYZ
abcdefghijklmnopqrstuvwxyz
-. 0123456789
← → CLR POS END
-----

```

- The name will appear at the top left corner.





- Please find the position you wish to display the name by using the 4 directional buttons, and then press the SETUP button.



- Please select 'END' and then press the SETUP button to complete ID input.

### 3) COLOR

- ① **AUTO** : This camera has a function which automatically changes to the appropriate mode for daytime or night-time. The COLOR mode is operated for daytime, and it converts to BW mode for night-time.

SPECIAL	
CAMERA ID	OFF
▶ COLOR	ON
SYNC	INT
MOTION DET	OFF
PRIVACY	OFF
MIRROR	OFF
SHARPNESS	ON
RESET	
RETURN	

#### Note

- When the AGC is turned off, COLOR does not operate.
- When an infrared light is used, there may be a problem with focusing.

### 4) SYNC

- " Sync " mode is fixed to INT in DC12V input power.

### 5) MOTION DETECTION

SPECIAL	
CAMERA ID	OFF
COLOR	ON
SYNC	INT
▶ MOTION DET	OFF
PRIVACY	OFF
MIRROR	OFF
SHARPNESS	ON
RESET	
RETURN	

- This product has a feature that allows you to observe movements of objects in 4 different areas on the screen, and the words 'MOTION DETECTED' appear on the screen when movement is detected; hence a single

- ② **ON** : The color mode is selected by default, and the modes do not change Automatically.

individual can conduct supervision efficiently.  
The camera detects an object's movement by sensing disparity of outline, and level of brightness and color.

- ① Please press the SETUP button.
  - OFF : MOTION DETECTION mode is cancelled.
  - ON : Any motion in the selected areas is observed.
- ② Please select the area you wish to observe from the 4 areas in AREA SEL mode.
- ③ Please select ON mode for the chosen area.
- ④ Please adjust the size of the area to be observed by using the UP, DOWN, LEFT or RIGHT button.
- ⑤ Please adjust the level of observation by using SENSITIVITY mode.

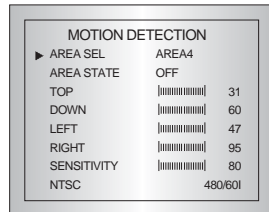

- Please press the SETUP button to save the changes and complete the setting.

## 6) PRIVACY

This mode conceals the areas you do not wish to appear on the screen.

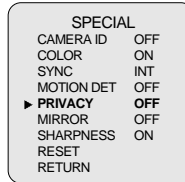

OFF : Cancels the PRIVACY mode

ON : Operates the PRIVACY mode.

- ① Please press the SETUP button.

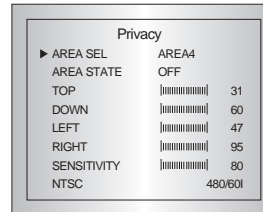

- ② Please select the area you do not wish to appear from the 4 areas in AREA SEL mode.
- ③ Please select ON mode for the chosen area.

④ Please adjust the size of the area to be concealed by using the UP, DOWN, LEFT Or RIGHT button.

### 7) MIRROR

SPECIAL	
CAMERA ID	OFF
COLOR	ON
SYNC	INT
MOTION DET	OFF
PRIVACY	OFF
▶ MIRROR	OFF
SHARPNESS	ON
RESET	ON
RETURN	

ON : Sets a horizontal image inversion

OFF : Cancels the inversion.

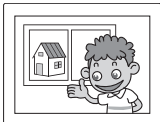

MIRROR ON

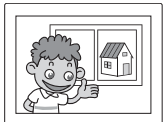

MIRROR OFF

### 8) SHARPNESS

SPECIAL	
CAMERA ID	OFF
COLOR	ON
SYNC	INT
MOTION DET	OFF
PRIVACY	OFF
MIRROR	OFF
▶ SHARPNESS	ON
RESET	
RETURN	

The outline of the video image becomes cleaner and more distinctive as the level of SHARPNESS increases. If the level goes up excessively, however, it may affect the video image and generate noise.



① The available range of level is 0 ~ 31.

### 9) RESET

Returns to the level which was set by the manufacturer for shipment.

### 10) RETURN

Saves the SPECIAL menu and returns to the SETUP menu.

## 7. Troubleshooting

If there are problems in operation, please refer to the items below. If the problem persists, please contact the agent you purchased this product from.

Problems	Troubleshooting
<b>Nothing appears on the screen.</b>	<ul style="list-style-type: none"> <li>• Please check the power connection.</li> <li>• Please check the video signal line connection.</li> <li>• Please check and make sure that the auto lens switch is set to DC (VIDEO) when using a VIDEO(DC) lens.</li> </ul>
<b>The video image is not clear.</b>	<ul style="list-style-type: none"> <li>• Please check if the lens is clean. Please clean the lens with a clean cloth or brush.</li> <li>• Please adjust the contrast feature of the monitor.</li> <li>• Please readjust the back focus of the camera.</li> </ul>
<b>The screen is dark.</b>	<ul style="list-style-type: none"> <li>• Please adjust the contrast feature of the monitor.</li> <li>• If you have an intermediate device, set the 75 / Hi-z properly, and check the terminals.</li> </ul>
<b>There is a problem with the camera operation.</b>	<ul style="list-style-type: none"> <li>• Please check if an auto iris lens is being used and adjust the brightness level.</li> </ul>

Problems	Troubleshooting
<b>The MOTION DETECTION function is not working.</b>	<ul style="list-style-type: none"> <li>• Please check if an appropriate power source to the camera complies with the manufacturer's standard requirement, or if the voltage keeps changing.</li> </ul>
<b>Colors are not quite right.</b>	<ul style="list-style-type: none"> <li>• Please check if 'MOTION DETECTION' mode is turned on.</li> <li>• Please check if the MD LEVEL is too low.</li> <li>• Please check the setting of the MD AREA.</li> </ul>
<b>The screen is flickering.</b>	<ul style="list-style-type: none"> <li>• Please check the 'WHITE BAL' setting</li> <li>• Please check if the camera is facing directly into sunlight or fluorescent light.</li> <li>• Please check if an auto iris lens is being used.</li> <li>• Please check the connection of the lens connector cable.</li> </ul>
<b>COLOR mode is not working.</b>	<ul style="list-style-type: none"> <li>• Please check if the AGC menu is set to the OFF position.</li> </ul>
<b>SENS-UP function is not working.</b>	<ul style="list-style-type: none"> <li>• Please check if the AGC menu is set to the OFF position.</li> <li>• Please check if the SHUTTER menu is set to MANUAL mode.</li> </ul>

## 8. Specifications

SIGNAL SYSTEM	NTSC	PAL
TOTAL / EFFECTIVE PIXEL	410K / 380K Pixels	470K / 440K Pixels
IMAGE SENSOR	1/3" SONY interline transfer CCD	
HORIZONTAL RESOLUTION	530 TV Line	
MINIMUM ILLUMINATION	0.3 Lux / F 1.2, 0.01Lux with Sensitive Up	
DAY & NIGHT	ON / AUTO	
OSD	Available	
LENS	CS Mount	
DNR	OFF/LOW/MIDDLE/HIGH	
SENS-UP	OFF / AUTO	
MOTION DETECTION	ON / OFF	
LUMINANCE S/N RATIO	More than 50dB (AGC Off)	
SYNC. SYSTEM	Internal	
WHITE BALANCE	ATW / AWC / Manual	
MIRROR	OFF / ON	
VIDEO OUTPUT	Composite output 75ohm terminated 1.0 Vpp, Y/C separate output	
SHUTTER SPEED	Auto/Manual (1/60~1/120,000)	Auto/Manual (1/50~1/100,000)
PRIVACY MASKING ZONE	OFF/ON (4 ZONES)	
OPERATING TEMPERATURE	- 10°C to 50°C / 30~90% RH	
SUPPLIED VOLTAGE	DC 12V, 50/60 Hz	
POWER CONSUMPTION	MAX. 180mA	
DIMENSIONS	61(W) x 55(H) x 104(D)mm	
WEIGHT	About 400g	



DISTRIBUTED BY